

YUEQING HONGYI ELECTRONICS CO., LTD
乐清市宏一电子有限公司

SPECIFICATION FOR APPROVAL

承认书

CUSTOMER 客户名称	
DESCRIPRION 产品名称	1.25 空中对接系列连接器
ITEM NO 编 号	HY-A12504 (A17)
DATE 日 期	2022-8-26

CUSTOMER ACKNOWLEDGEMENT SEAL

客户承认印签

(APPROVAL) 核准	(ENGINEERING) 工程	(PURCHASE) 采购	(QUALITY) 品质
承认结果： <input type="checkbox"/> 通过 <input type="checkbox"/> 不通过 <input type="checkbox"/> 重新送样			

IS09001

IS014001

IS045001

IATF16949 体系认证

ADD: No. 30, Wenjing Road, Houyu village, Shifan street, Yueqing City, Zhejiang Province

地址：浙江省乐清市石帆街道后屿文景路 30 号

TEL:0577-62380521

FAX: 0577-62381979 P.C:325608

http: //www.zhehongyi.com

E-MAIL:yaohongxiao88@126.com

产 品 承 认 书 目 录

1、封面	1-1
2、修订履历	2-2
2、目录	3-3
3、技术规范	4-8
4、产品图纸	9-12

PRODUCT SPECIFICATION

产品规范

1、Scope

适用范围

This specification includes the following specifications, including the specification of 1.25mm pitch 1.25 air butt strip connector series connector
本规范包括下列此种规格包括 1.25mm 间距 1.25 空中对接系列连接器规格说明

2、Appearance and Dimension

外观及尺寸

2.1 Appearance: Product surface without defect, dirt, crack, and mechanical damage, Contact without rust, plating not oxidized and not peeled.

产品表面不应有对制品有害的缺陷、污垢、裂痕及机械损伤；接触件无锈蚀、镀层氧化脱落等现象

2.2 Dimension: According to drawings

外形尺寸：依照附图

3、Disposal of Material and surface

材料与表面处理

Specification 规格内容	Material 材质	Finish 表面处理	Environmental protection grade 环保等级
Terminal 端子(公)	Phosphor bronze 磷铜 厚 0.15mm	Tin Plating: 2.5-5 μ m 镀锡: 2.5-5 μ m	RoHS2.0
Terminal 端子(母)	Phosphor bronze 磷铜 厚 0.15mm	Tin Plating: 2.5-5 μ m 镀锡: 2.5-5 μ m	
Housing 胶壳(公)	PA66 UL94V-0	Color: White 颜色: 白色	
Housing 胶壳(母)	PA66 UL94V-0	Color: White 颜色: 白色	

4、Ratings and applicable wires

额定等级

Item 项目	Standard 规格
Rated Voltage 额定电压	125V AC/DC
Rated Current 额定电流	1A AC/DC
Ambient temperature Range 使用温度范围	-25°C- +85°C
Applicable wire insulation 适用线径	AWG28#-32#

5、Electrical Performance

电气性能

N0. 序号	Ltem 项目	Test mode 试验方法	Requirement 技术要求
5.1	ContactResistance 接触电阻	Male female cooperation, open voltage less than 20mV, current 100mA detection connector at both ends 公母配合, 开放电压20mV 以下, 电流100mA 检测连接器连接器两端	Initial:20mΩ Max 初始: 20mΩ Max After Test: 30mΩ Max 试验后: 30mΩ Max
5.2	withstandvoltage 耐电压	Mate connectors, apply 500V AC for 1 minute between adjacent terminal or ground 公母配合, 在相邻端子, 端子与地片之间, 使用500V 的交流电1 分钟, 检测连接器	No Breakdown and Flashover 外观无损伤, 无打火花
5.3	InsulationResistance 绝缘电阻	Mate connectors, apply 500V DC between adjacent terminal or ground 公母配合, 在相邻端子, 端子与地片之间, 使用500V 的直流电, 检测连接器	100MΩ Min

6、机械性能

Mechanical Performance

N0. 序号	Ltem 项目	Test mode 试验方法		Requirement 技术要求
6.1	Terminal crimping wire strength 端子压接导线强度	Fix the crimped terminal, apply axial pull out force on thewire 固定铆线后的端子, 使电线与端 子分离时所需的最小力量	AWG#28 wire AWG#28 导线	13N Min
			AWG#30 wire AWG#30 导线	8N Min
			AWG#32 wire AWG#32 导线	6N Min
6.2	Terminal/ Housing Retention Force 端子保持力	Apply axial pull out force at the speed rate of $25.4\pm 3\text{mm}/\text{minute}$ on the terminal assembled in the Housing 以每分 $25.4\pm 3\text{mm}$ 的速率, 将端子从Housing 内轴 向拔出力		Per contact: 8N Min 单一接触点: 8N Min
6.3	Insertion & withdraw Force 插拔力	Insert and withdraw Connectors at the speed rate of $25.4\pm 3\text{mm}/\text{minute}$ 以每分 $25.4\pm 3\text{mm}$ 的速率插入和拔出		Refer to paragraph 8 参照第 8 项

7、Endurance Characteristics:

环境性能

N0. 序号	Ltem 项目	Test mode 试验方法	Requirement 技术要求	
7.1	Repeated Insertion/ Withdrawal 重复插拔	When mated up to 30 cycles repeatedly by the rate of 10 cycles per minute 以每分 10 次的速率, 将公母插 拔 30 次	Contact Resistance 接触电阻	30 m Ω Max

NO. 序号	Ltem 项目	Test mode 试验方法	Requirement 技术要求	
7.2	Temperature Rise 温升测试	Mating connectors shall be energized at rating current until thermal stability is achieved, and then measured the temperature rise 公母连接器配合后，加载额定电流直到温度上升到稳定状态，然后再测量温升	Temperature Rise 温升测试	30°C Max
7.3	Vibration test 振动测试	Amplitude: 1.5mm P-P Sweep time: 10~55~10 HZ in 1 minute Duration: 2 hours in each X.Y.Z axials 振幅: 1.5mm P-P 时间: 10~55~10 HZ in 1 minute 持续时间: 每轴向 2 小时	Appearance 外观	No damage 无异常
			Contact Resistance 接触电阻	30 mΩ Max
			Discontinuity 瞬断	1 micro-second Max.
7.4	Heat Resistance 耐热性	85±2°C,96 hours	Appearance 外观	No damage 无异常
			Contact Resistance 接触电阻	30 mΩ Max
7.5	Cold Resistance 耐寒性	-25±3°C,96 hours	Appearance 外观	No damage 无异常
			Contact Resistance 接触电阻	30 mΩ Max
7.6	Humidity 耐湿性	Temperature: 60±2°C Relative Humidity: 90~95% Duration: 96 hours 温度: 60±2°C 湿度: 90~95%(RH) 持续时间: 96 hours	Appearance 外观	No damage 无异常
			Contact Resistance 接触电阻	30 mΩ Max
			Withstand Voltage 耐电压	No Breakdown and Flashover 外观无损伤, 无打火花
			Insulation Resistance 绝缘电阻	100MΩ Min

N0. 序号	Ltem 项目	Test mode 试验方法	Requirement 技术要求	
7.7	温度变化 Temperature Cycling	5 cycles of: a) -25°C 30 minutes b) +85°C 30 minutes 从-25°C持续30 分钟升至+85°C持续30 分钟, 循环5 次	Appearance 外观	No damage 无异常
			Contact Resistance 接触电阻	30 mΩ Max
7.8	Salt spray 盐雾	24±1 hours exposure to a salt spray from the 5±1% solution at 35±2°C 在温度35±2°C, 盐水浓度5±1%下, 盐水 喷雾24±1 小时	Appearance 外观	No damage 无异常
			Contact Resistance 接触电阻	30 mΩ Max

8、INSERTION/WITHDRAWAL FORCE 综合插入力及拔出力

No. of CTK PIN 数	At Initial 初始值		At 30th 插拔 30 次	No. of CTK PIN 数	At Initial 初始值		At 30th 插拔 30 次
	I. F (N Max) 插入力	W. F (N Min) 拔出力	W. F (N Min) 拔出力		W. F (N Min) 拔出力	W. F (N Min) 拔出力	W. F (N Min) 拔出力
2	20	2.8	1.8	12	70	6.5	5.5
3	25	3.0	2.0	13	75	6.8	5.8
4	30	3.3	2.3	14	80	7.1	6.1
5	35	3.8	2.8	15	85	7.4	6.4
6	40	4.3	3.3	16	90	7.7	6.7
7	45	4.8	3.8	17	95	8.0	7.0
8	50	5.3	4.3	18	100	8.3	7.3
9	55	5.6	4.6	19	105	8.6	7.6
10	60	5.9	4.9	20	110	8.9	7.9
11	65	6.2	5.2				

REV.	日期	ECN NO.	变更内容	制图
	DATE		DESCRIPTION	DRAWN

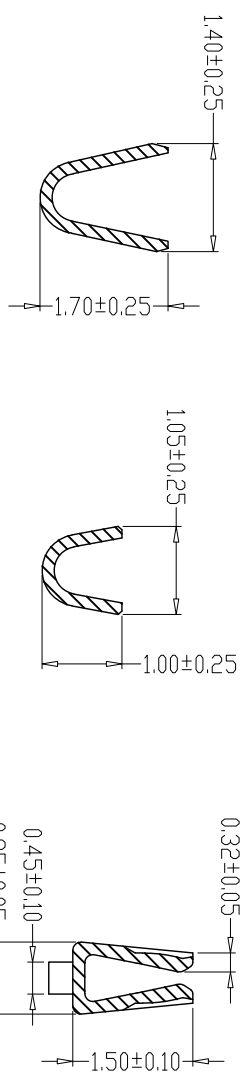
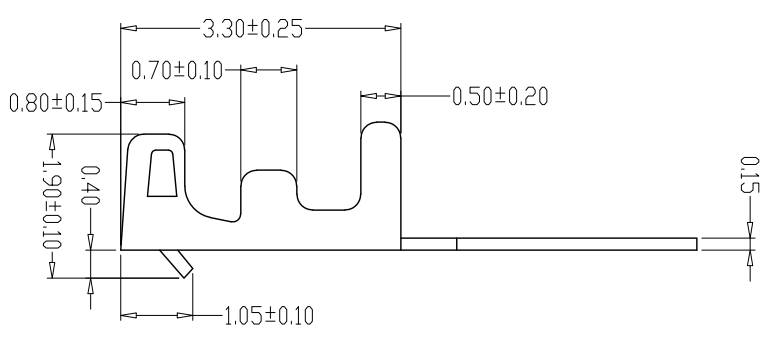
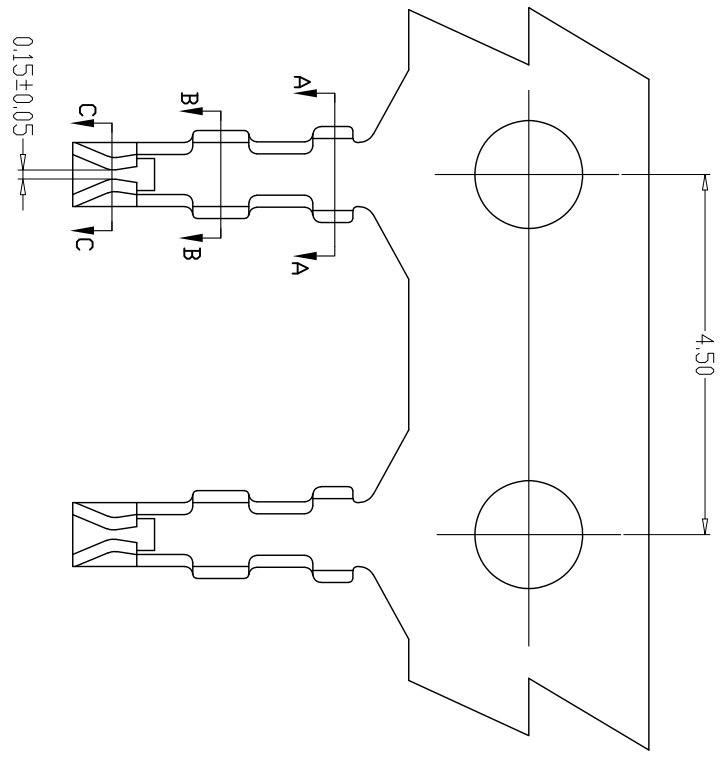

- SPECIFICATIONS**
- 1、Current Rating: 1A AC, DC
 - 2、Voltage Rating: 125V AC, DC
 - 3、Temperature Range: -25°C~+85°C
 - 4、Contact Resistance: 20mΩ Max
 - 5、Insulation Resistance: 100MΩ Min
 - 6、Withstanding Voltage: 500V AC/minute
 - 7、Material: Phosphoric bronze Tin-plated
 - 8、Applicable Wire Sizes: AWG#28~32#

GENERAL TOLERANCE		制图		张迎春	
X.X±0.25	X.±2°	DRAWING	2022、08、25	料号	A12502-T
X.XXX±0.10		审核	钱岳生	品名	1.25端子
X.XX±0.20		CHECK	2022、08、26	TITLE	
		核准	张名	客户料号	
		APPROVAL	2022、08、26	CITM. NO.	
		单位	MM	比例	1:1
		UNITS	SCALE		

乐清市宏一电子有限公司
YueQing HongYi Electronics Co., Ltd

REV.	DATE	ECN NO.	变更内容 DESCRIPTION	制图 DRAWN

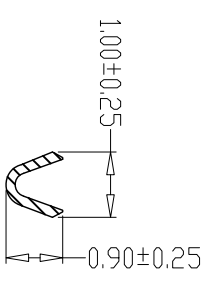
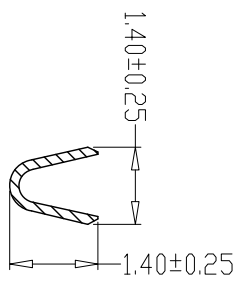
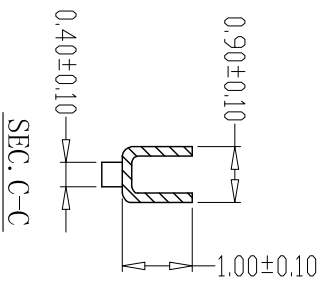
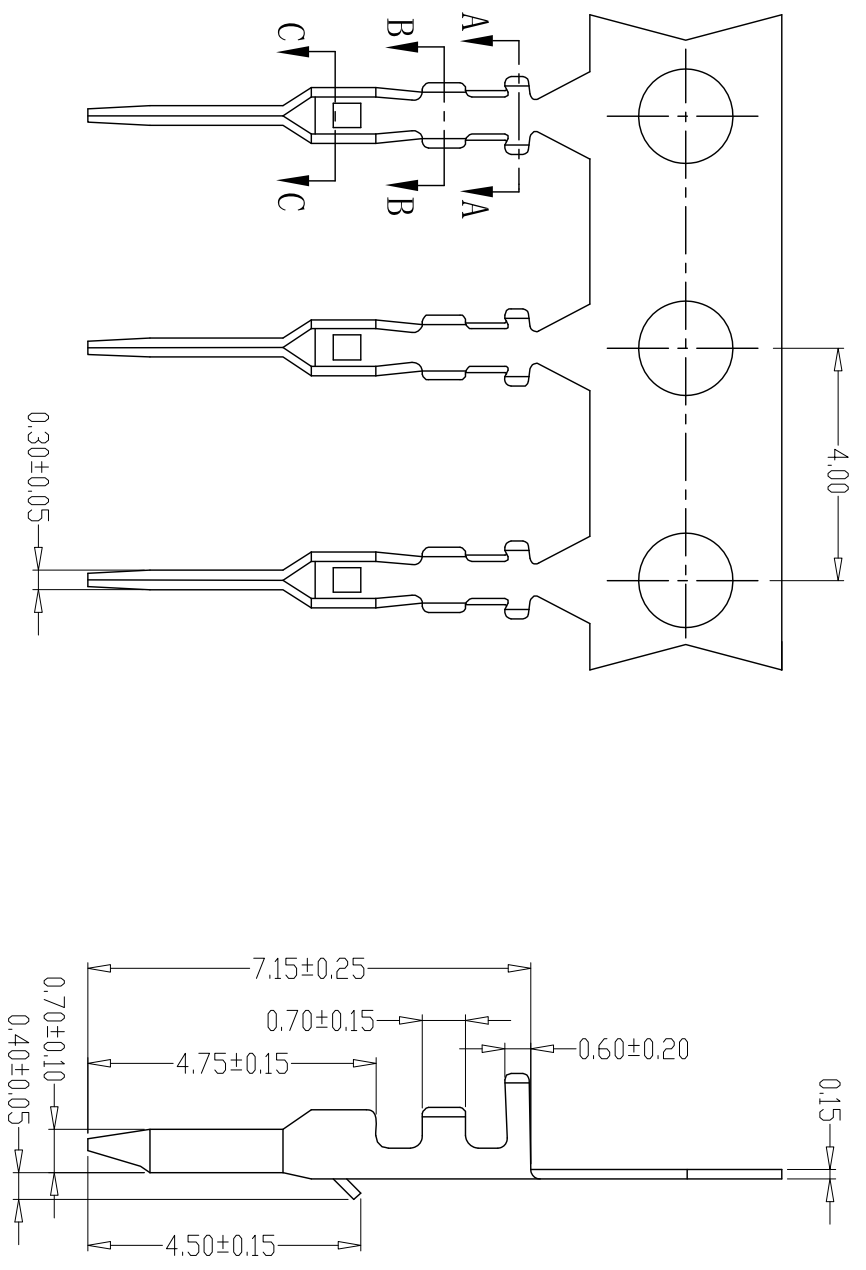

SPECIFICATIONS

- 1、 Current Rating: 1A AC, DC
- 2、 Voltage Rating: 125V AC, DC
- 3、 Temperature Range: -25°C~+85°C
- 4、 Contact Resistance: 20mΩ Max
- 5、 Insulation Resistance: 100MΩ Min
- 6、 Withstanding Voltage: 500V AC/minute
- 7、 Material: Phosphoric bronze Tin-plated
- 8、 Applicable Wire Sizes: AWG#28~32#

GENERAL TOLERANCE		制图 DRAWING		料号 PART NO.		版本 REV.	
X.X±0.25	X.±2°	张迎春	2022. 08. 25	A12504-T	A		
X.XXX±0.10		钱岳生	2022. 08. 26	1. 25空中对接端子(公端)			
X.XX±0.20		张名	2022. 08. 26	客户料号			
		核 准		CITM. NO.			
		单 位					
		MM					
		SCALE	1:1				

乐清市宏一电子有限公司
Yueqing HongYi Electronics Co., Ltd

版本	日期	ECN NO.	变更内容	制图
REV.	DATE	DESCRIPTION	DESCRIPTION	DRAWN

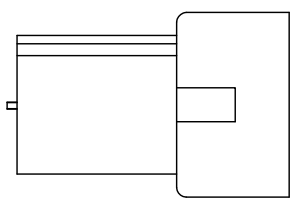
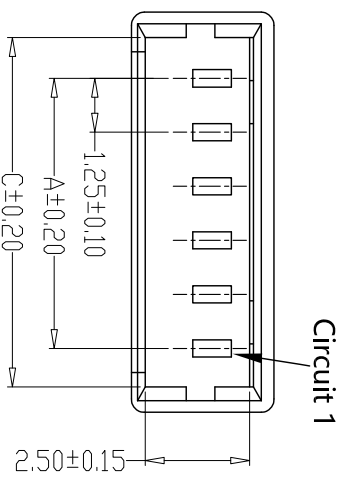

02P~03P

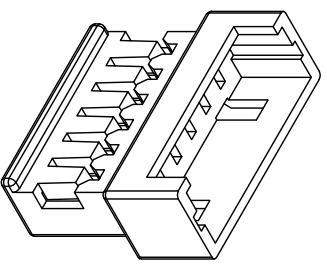

- SPECIFICATIONS
- 1、Current Rating: 1A AC, DC
 - 2、Voltage Rating: 125V AC, DC
 - 3、Temperature Range: -25°C~+85°C
 - 4、Contact Resistance: 20mΩ Max
 - 5、Insulation Resistance: 100MΩ Min
 - 6、Withstanding Voltage: 500V AC/minute
 - 7、Material: PA66, UL94V-0

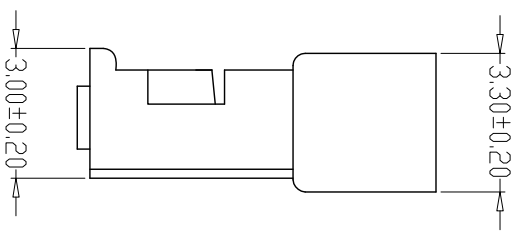
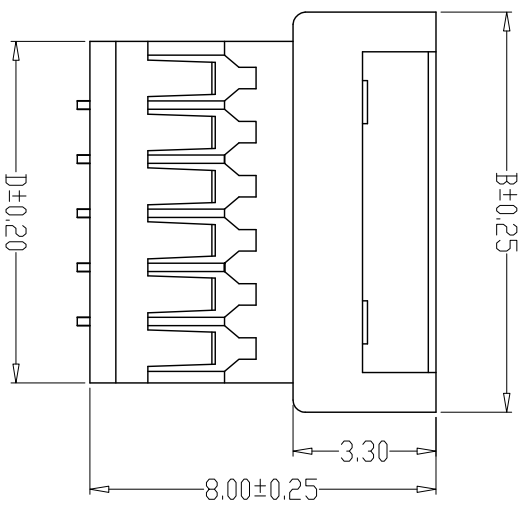

04P~16P

PIN	尺寸 (mm)			
	A	B	C	D
-02R	1.25	4.25	3.15	2.95
-03R	2.50	5.50	4.40	4.20
-04R	3.75	6.75	5.65	5.45
-05R	5.00	8.00	6.90	6.70
-06R	6.25	9.25	8.15	7.95
-07R	7.50	10.50	9.40	9.20
-08R	8.75	11.75	10.65	10.45
-09R	10.00	13.00	11.90	11.70
-10R	11.25	14.25	13.15	12.95
-11R	12.50	15.50	14.40	14.20
-12R	13.75	16.75	15.65	15.45
-13R	15.00	18.00	16.90	16.70
-14R	16.25	19.25	18.15	17.95
-15R	17.50	20.50	19.40	19.20

GENERAL TOLERANCE		制图		料号		版本	
X.X±0.25	X.±2°	DRAWING	张迎春	PART NO.	A12504-nR	REV.	A
X.XXX±0.10		CHECK	钱岳生	TITLE	1.25空中对接(公壳)	SHEET	1/1
X.XX±0.20		APPROVAL	张名	CITM. NO.			
		单位	2022.08.26	比例	1:1		
		MM	SCALE				

乐清市宏一电子有限公司
Yueqing HongYi Electronics Co., Ltd

REV.	日期	ECN NO.	变更内容	制图
	DATE		DESCRIPTION	DRAWN

- SPECIFICATIONS**
- 1、Current Rating: 1A AC, DC
 - 2、Voltage Rating: 125V AC, DC
 - 3、Temperature Range: -25°C~+85°C
 - 4、Contact Resistance: 20mΩ Max
 - 5、Insulation Resistance: 100MΩ Min
 - 6、Withstanding Voltage: 500V AC/minute
 - 7、Material: PA66, UL94V-0

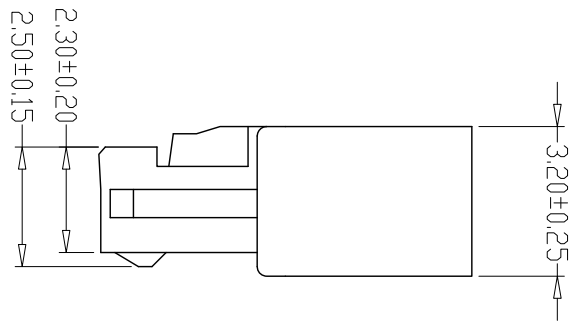
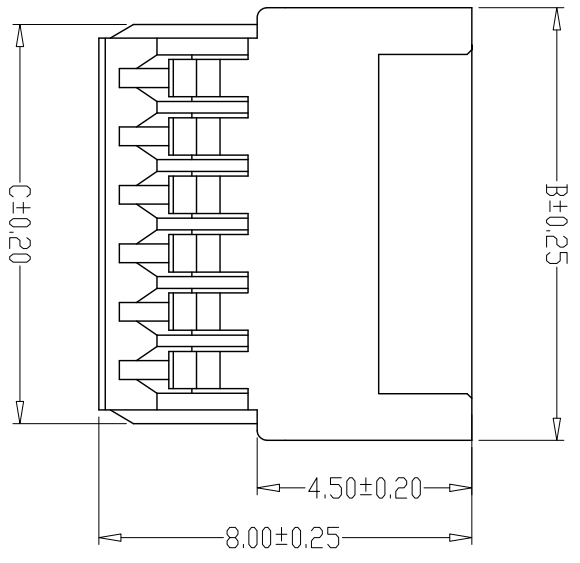
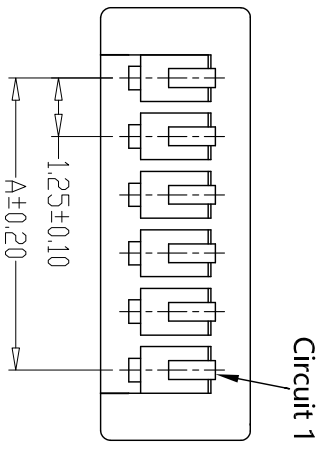
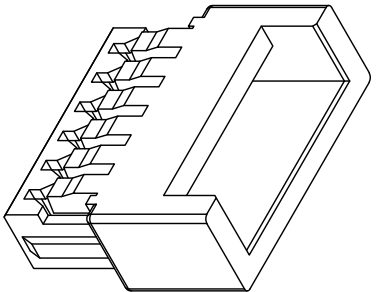

PIN	尺寸 (mm)		
	A	B	C
-02P	1.25	4.25	3.60
-03P	2.50	5.50	4.85
-04P	3.75	6.75	6.10
-05P	5.00	8.00	7.35
-06P	6.25	9.25	8.60
-07P	7.50	10.50	9.85
-08P	8.75	11.75	11.10
-09P	10.00	13.00	12.35
-10P	11.25	14.25	13.60
-11P	12.50	15.50	14.85
-12P	13.75	16.75	16.10
-13P	15.00	18.00	17.35
-14P	16.25	19.25	18.60
-15P	17.50	20.50	19.85

GENERAL TOLERANCE		制 图		料号	
X.X±0.25	X.±2°	DRAWING	张迎春	PART NO.	A12504-nP
X.XXX±0.10		审 核	钱岳生	品 名	1.25空中对接(母壳)
X.XX±0.20		CHECK	2022.08.26	TITLE	
		核 准	张 名	客户料号	
		APPROVAL	2022.08.26	CITM.NO.	
		单 位	MM	比 例	1:1
		单 位	SCALE		

乐清市宏一电子有限公司
Yueqing HongYi Electronics Co., Ltd